

SCHEDULE F

**REGULATIONS, STANDARDS AND SPECIFICATIONS FOR
THE DESIGN AND CONSTRUCTION OF SANITARY SEWERS**

This is Schedule F of the Corporation of the Village of
Lytton Subdivision and Development Servicing Bylaw No.
483, 1998.

Clerk

M. Madigan

SCHEDULE F

REGULATIONS, STANDARDS AND SPECIFICATIONS FOR THE DESIGN AND CONSTRUCTION OF SANITARY SEWERS

F - 1.0 GENERAL

- F - 1.01** Where a sanitary sewage collection and disposal system is required, sanitary sewer facilities including gravity sewer mains, pump stations and force mains, manholes, service connections and all related appurtenances shall be provided.

A sewer service lateral shall be installed where required to provide a connection to each parcel to be created by the subdivision and to any other existing or possible future parcels which can be serviced from mains installed by or for the subdivision. The routing of sewers shall be in accordance with the directions of the Approving Officer.

Through areas where connection to the community sanitary sewer system is not feasible as determined by the Approving Officer, a dry sewage collection system shall be installed for future connection to the Village's sewage collection system, on-site treatment and disposal system shall be designed and constructed in accordance with this Bylaw and the requirements of the Ministry of Environment, Lands & Parks with respect to sewage treatment and disposal.

F1.02 Approval of Engineering Drawings Required Prior to Construction

Prior to construction, engineering drawings prepared in accordance with the Village's specification for drawings contained in Schedule J showing detailed design of the necessary works shall be submitted together with Technical Specifications to the Approving Officer for approval. No construction of sanitary sewers shall commence until the drawings have been approved by the Approving Officer and the Owner advised accordingly in writing. Engineering drawings shall show alignment and size of pipes, proposed grades, distances between manholes, manhole invert elevations, existing ground line and proposed final ground line over pipe, location of all service connections to the property line, all easements, lift stations, force mains, pipe bedding requirements and all other details which may be required by the Village Director of Planning and Engineering.

PLOT DATE: 98/04/30 9:58am RH

PROJ. CAD FILE No.: J:\STUDEN\LYTTON\F-1.DWG

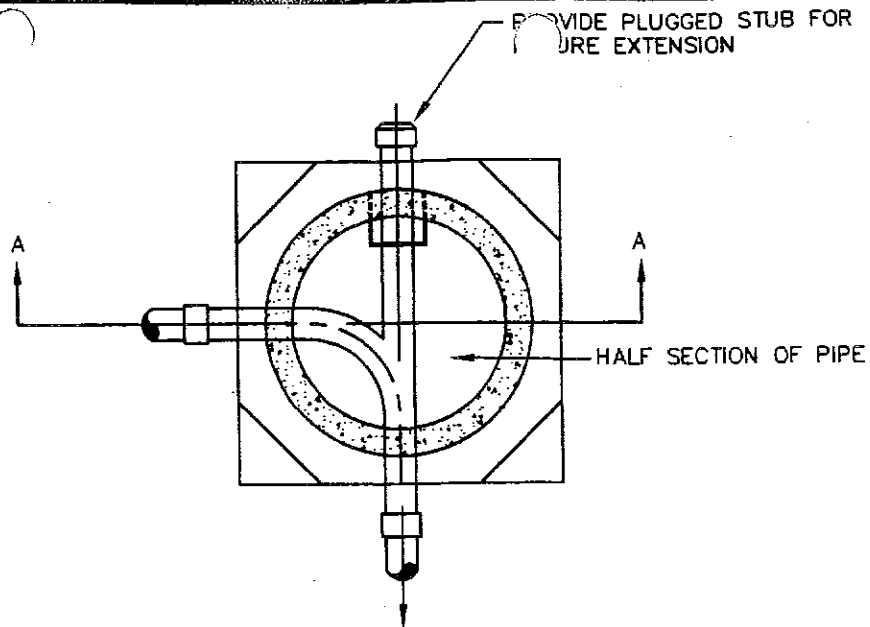

PLAN

PRECAST CONCRETE RINGS OR BRICK FILLER RING, MORTAR IN AND OUT TO SUIT GRADE, TWO LAYERS MAXIMUM

MANHOLE FRAME AND COVER TILT TO MATCH GRADE AND CROWN OF ROAD

ENTRANCE AND LADDER TO BE PLACED OVER MAIN CHANNEL ON UPSTREAM SIDE.

PRECAST CONCRETE LIDS REINFORCED TO H-20 HWY LOADING

PRECAST REINFORCED CONCRETE BARREL 1050mm MINIMUM

RUNGS AT 300 o/c CAST IN WALL OF BARREL SECTION. FIRST RUNG 500mm FROM FINISHED GRADE

JOINTS TO BE WATERTIGHT USE BITUMASTIC SEALANT

FIBREGLASS LINER "GU" OR EQUAL

GROUT ALL AROUND

100mm

25 MPA CONCRETE BASE

GRANULAR BASE

WHERE MANHOLE BASE EXCAVATION EXTENDS BEYOND BASE DIMENSIONS THE OVEREXCAVATION SHALL BE FILLED WITH CONCRETE 100mm BELOW THE BOTTOM OF THE PIPE AND THE WIDTH OF THE TRENCH. ALL POURED IN PLACE CONCRETE TO BE 25 MPA

SECTION 'A-A'

UNDISTRUBED SOIL

VILLAGE OF LYTTON

SCALE: NOT TO SCALE

TITLE: TYPICAL MANHOLE & BASE DETAILS FOR SEWER UP TO 400mm DIA.

DATE DRAWN: MAR. 1998
LATEST REVISION DATE: MAR. 1998

APPROVED BY: *Amelia*

SECTION: SCHEDULE F SANITARY SEWER	REVISION No. 0	DWG No. F-1
---------------------------------------	-------------------	----------------

PLOT DATE: 98/04/30 10:15am RH

PROJ. CAD FILE No.: J:\STDDET\LYTSTD\F-2.DWG

IN ALL CASES, OUTGOING PIPE TO GO STRAIGHT THROUGH M.H. WITH 1/2 PIPE TO OPPOSITE WALL: INCLUDING DEAD END MANHOLES

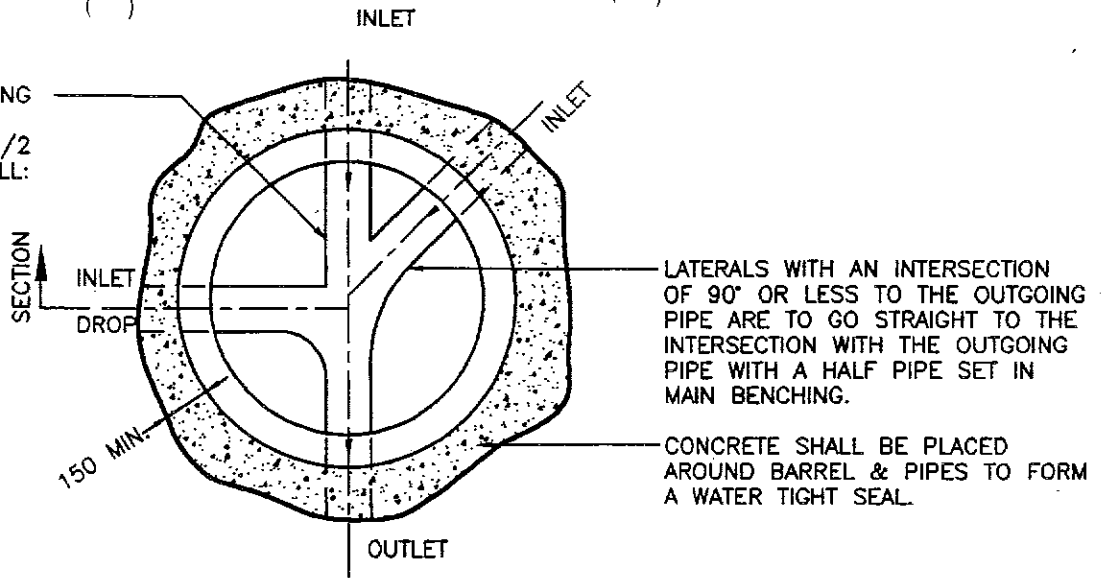

PLAN OF MANHOLE

INLET FLOW DROPS INTO MAIN BENCHING

NOTE: DROPS BETWEEN 200mm AND 600mm ARE TO BE AVOIDED BY ADJUSTING GRADES. DROPS OF 600mm OR GREATER SHALL BE BY AN EXTERNAL DROP STRUCTURE.

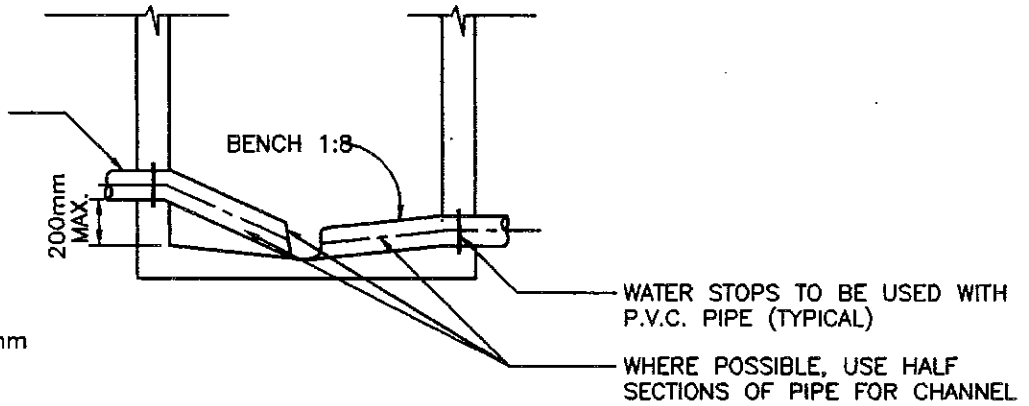

SECTION THROUGH MANHOLE

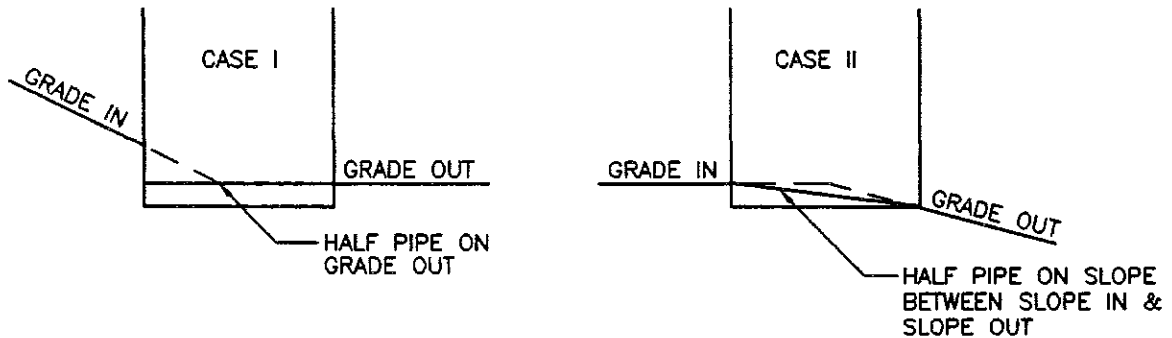

VILLAGE OF LYTTON

SCALE: NOT TO SCALE
 DATE DRAWN: MAR. 1998
 LATEST REVISION DATE: MAR. 1998
 APPROVED BY: *Amadio*

TITLE: MANHOLE BENCHING & CHANNELLING

SECTION: SCHEDULE F SANITARY SEWER
 REVISION No. 0
 DWG. No. F-2

F- 2.0 DESIGN CRITERIA

F - 2.01 Pipe Capacity

Sanitary sewer facilities constructed in a subdivision shall be designed to provide sufficient capacity to carry the required quantity of sewage flow from the fully developed upstream contributing area, as defined by the Approving Officer.

Sewage design flows shall be based on the equivalent population of the contributing area as determined by the Approving Officer but no less than 66 persons per hectare with an average per capita flow of 500 litres per day. A peaking factor calculated using the Harmon Peak Factor curve shall be applied to the average flow as follows:

$$\text{Peak Factor} = 1 + \frac{14}{4 + P^{1/2}}$$

Where P = equivalent contributing population in thousands.

An infiltration rate of 5,000 litres per hectare per day shall be used. In areas where the water table is higher than the sewer main inverts, 8000 litres per hectare per day shall be used.

The peaking factor shall be applied to the sanitary contribution only and not to the infiltration allowance.

Pipe sizes shall be selected so that sewers flow 2/3 to 3/4 full at peak hour design flow.

F - 2.02 Minimum Velocity and Design Grade

Minimum velocity for pipe flowing full or half full shall be 0.6 metres per second. Minimum grades are as follows, assuming a pipe roughness coefficient "n" of 0.013:

**TABLE F-1
MINIMUM PIPE SIZES AND GRADES**

<u>Pipe Dia.</u>	<u>Min. Grade</u>	<u>Pipe Dia.</u>	<u>Min. Grade</u>
100 mm	2.00%	375 mm	0.15%
150 mm	0.60%	400 mm	0.14%
200 mm	0.40%	450 mm	0.12%
250 mm	0.28%	525 mm	0.095%
300 mm	0.22%	600 mm	0.080%
350 mm	0.17%		

There shall be no change in the grades of pipe between manholes.

F - 2.03 Sizing of Sewer mains

The minimum pipe size for all sewer mains shall be 150 mm.

No reduction of pipe size shall be made downstream, irrespective of pipe grade.

F - 2.04 Depth of Cover

The depth of the main shall be sufficient to provide all service connection piping with a minimum cover of 1.8 m to top of the service piping anywhere within the finished right-of-way. Sanitary mains shall be designed such that gravity drainage is possible from the full basement level of all parcels. In no instance shall the minimum cover over the crown of gravity mains be less than 1.8 m and over forcemains less than 1.8 m.

F - 2.05 Manhole Spacing

Manholes shall be installed at a maximum spacing of 120 metres and in the following locations:

- .1 at the end of each line where cleanouts are not provided;
- .2 at all changes in grade and/or alignment (for non curvilinear sewers);
- .3 at all changes in pipe size;
- .4 at all pipe junctions;
- .5 at all intersections.
- .6 at the beginning and end of pipe curvature for curvilinear sewers

Manholes shall normally be constructed in accordance with the details as shown on the Standard Drawings. In cases where these details will not suffice, a detailed design drawing must be approved by the Approving Officer.

Drop manholes on sanitary sewers may be allowed where particular circumstances preclude the use of normal manholes and where invert elevations differ by more than 600 mm.

The relative elevations of sanitary sewers entering and leaving a manhole are to be such as to ensure that the manhole does not substantially reduce the hydraulic capacity of the system. Minimum fall through the manhole where liners are installed shall be 20 mm.

PLOT DATE: 98/04/30 10:15am RH

PROJ. CAD FILE No.: J:\STDD\LYTTON\F-3.DWG

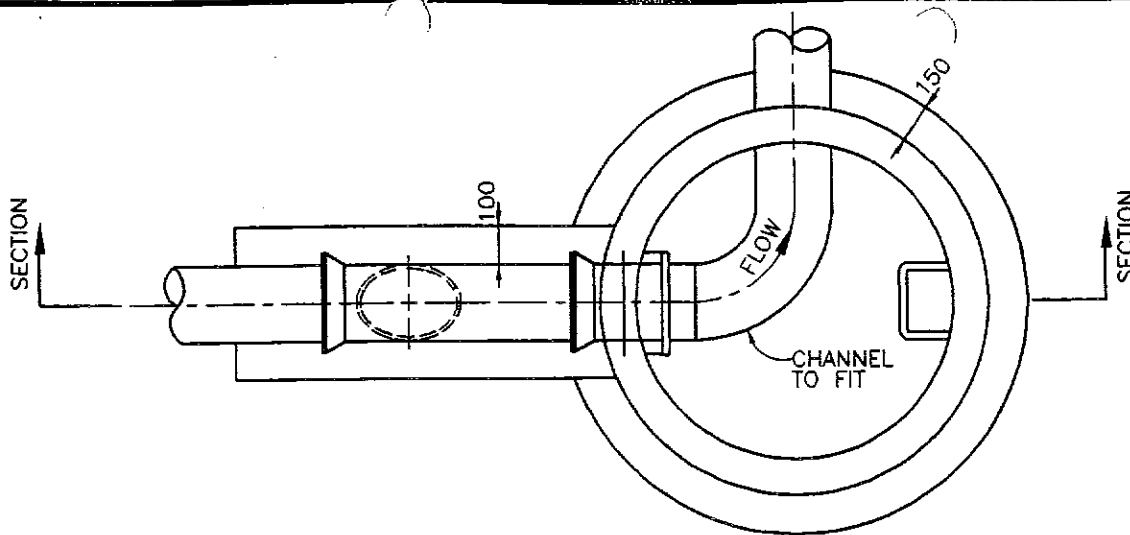

PLAN

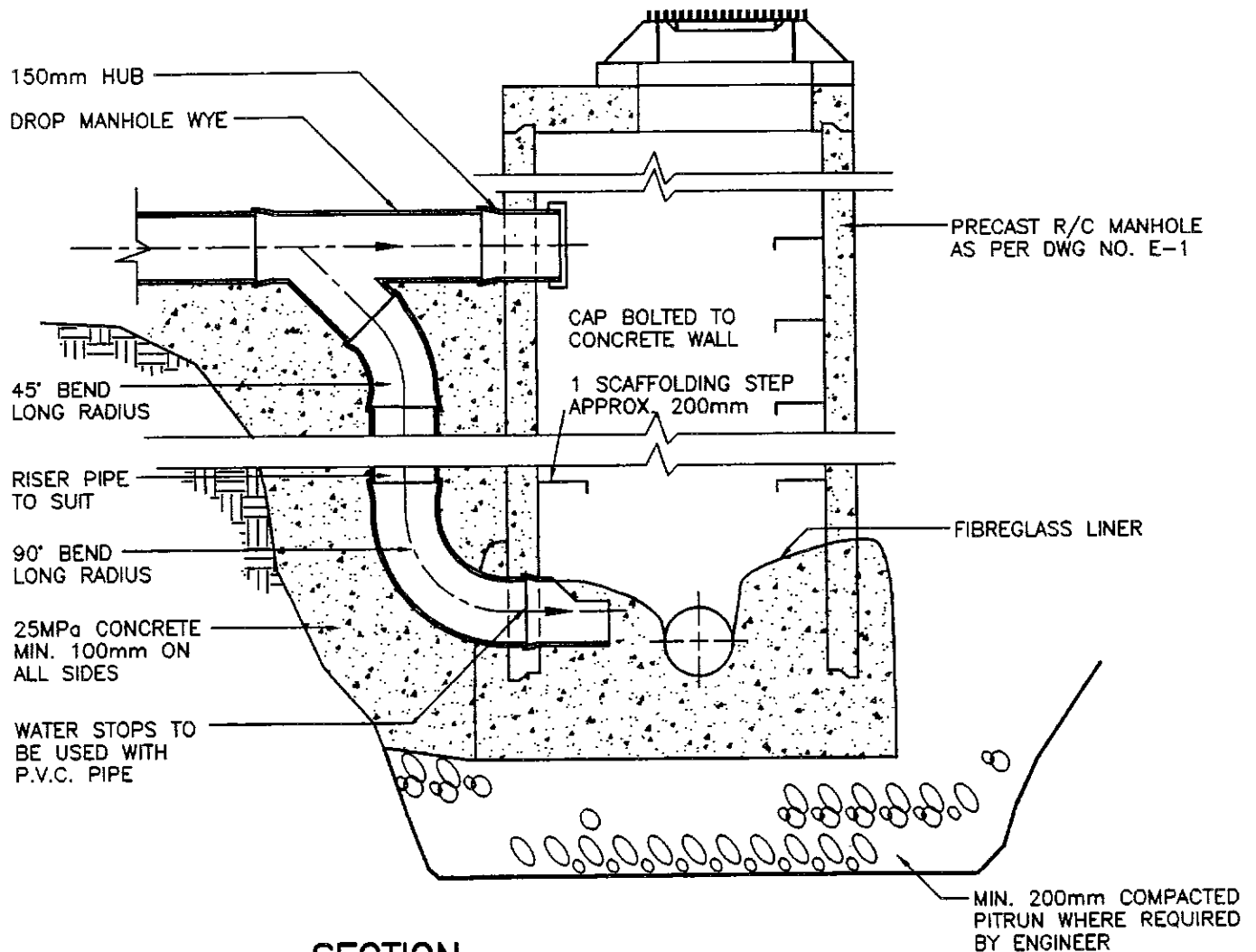

SECTION

VILLAGE
OF
LYTTON

SCALE: NOT TO SCALE

DATE DRAWN:
MAR. 1998

LATEST REVISION
DATE:
MAR. 1998

APPROVED BY:
Madia

TITLE:
EXTERIOR DROP MANHOLE

SECTION: SCHEDULE F
SANITARY SEWER

REVISION No.
0

DWG.No.
F-3

PLOT DATE: 98/04/30 10:15am RH

PROJ. CAD FILE No.: J:\STDDET\LYTTON\F-4.DWG

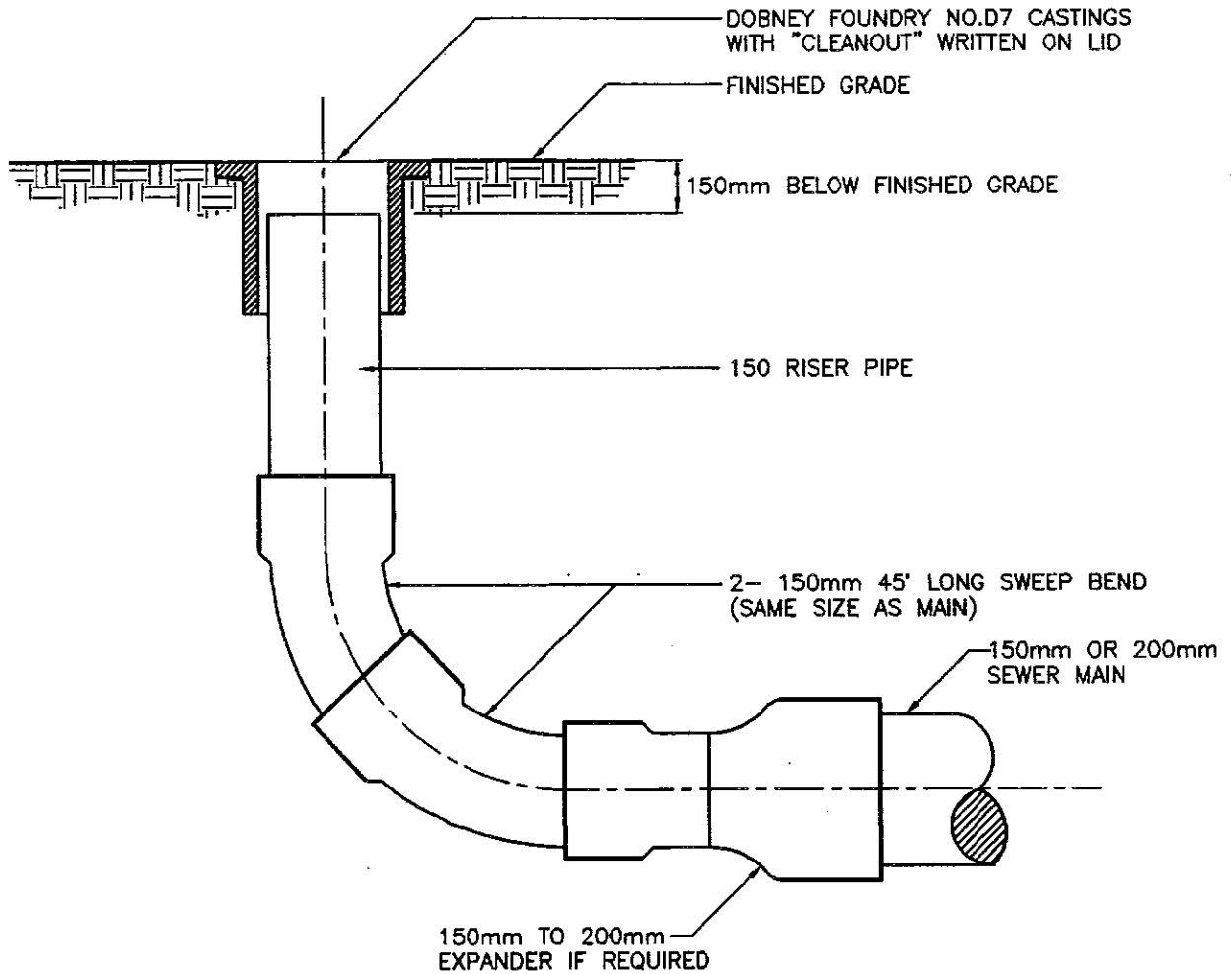

NOTE:
ALL PIPE MATERIALS SHALL
BE P.V.C.

VILLAGE
OF
LYTTON

SCALE: NOT TO SCALE

DATE DRAWN:
MAR. 1998

LATEST REVISION
DATE:
MAR. 1998

APPROVED BY:

Amadiq

TITLE:

SEWER CLEANOUT FOR
150mm & 200mm SANITARY
SEWER TERMINALS

SECTION: SCHEDULE F
SANITARY SEWER

REVISION No.
0

DWG.No.
F-4

F - 2.06 Cleanouts

Cleanouts rather than manholes, may be permitted at the end of non-extendible sewer mains in non-travelled areas with the consent of the Approving Officer. Cleanouts shall be constructed in conformance with the applicable Standard Drawing.

F - 2.07 Service Connections

The diameter of sewer services shall be determined by the Design Engineer, subject to the approval of the Approving Officer, but in no case shall the size be less than 100 mm diameter.

Sewer services shall be installed in an individual trench 3 m from the water service, each lot in accordance with the applicable Standard Drawings. Through areas of steep topography and road grades, sewer services may be installed 3.0 m from the lowest (elevation) lot corner.

Service connections shall be made with an approved branch wye and be installed in a straight line and at a uniform grade from the terminus at the property line to the 45 degree long radius bend at the main. An approved wye saddle may only be used to connect a 100 mm diameter service to an existing main. The minimum pipe grade for sewer service pipes shall be:

- 2% for 100 mm service pipe
- 1% for 150 mm service pipe

In areas where the depth of the service pipe at the main is less than that of the main, service risers shall be constructed consistent with the applicable Standard Drawing.

For services 200 mm and larger, a manhole shall be installed at the intersection of the main and the service. A wye or saddle will not be accepted for services 200 mm or larger.

A Le-Ron Plastics inspection chamber shall be installed 300 mm from the property line on all services, as shown on the applicable Standard Drawing.

F - 2.08 Location of Sewer Mains

Sanitary sewer mains shall, wherever possible be located in the road right-of-way as shown on the Standard Drawings. Where the location of the sewer main within the road right-of-way is not practical due to topography or other factors, the sewer main shall be located in a utility right-of-way registered in favour of the Corporation of the Village of Lytton and having a width of not less than 6.0 metres. The Approving Officer may require a utility right-of-way wider than 6.0 metres in the case where services in

addition to sanitary sewer will be placed in the same right-of-way or where the depth of the sewer main requires a wider easement. There shall be a minimum clear lateral distance between the outside walls of sanitary sewers and storm sewers of 0.75 m.

The entire length and width of sanitary sewer main easements shall be graded to permit access by maintenance vehicles.

F - 2.09 Alignment of Sewer Mains

Sewer mains shall be installed at least 3.5 m between the centerline of the watermain and the centerline of an adjacent sanitary sewer main and generally be designed to follow a straight alignment between manholes. Curved alignments within rights-of-way shall be subject to the approval of the Approving Officer and provided that the pipe is set at a grade greater than the specified minimum and pipe alignment is at a parallel offset with an established boundary. In these cases, the radius of curvature shall be not less than twice time the minimum radius recommended by the pipe manufacturer. Pipe bends shall be used where required to keep curved sewers on the appropriate alignment.

F - 2.10 Sanitary Force Mains and Lift Stations

Pre-design Requirements

The objective of the Corporation of the Village of Lytton is to minimize the number of sewage lift stations required and thoroughly evaluate other options to avoid lift stations wherever practical. The Design Engineer shall obtain approval from the Approving Officer as to the siting of the lift station.

Prior to commencing detailed design of a lift station, the Design Engineer shall submit a pre-design report that addresses the design considerations of the station to the Approving Officer. Approval of the pre-design concepts must be obtained prior to the Design Engineer commencing detailed design.

This requirement covers both dry well and submersible sewage lift stations. Larger capacity sewage lift stations or lift stations with special design or siting requirements may require additional assessment and review of criteria.

The location and layout of a lift station shall include, at minimum, an assessment of the following basic design considerations:

- .1 Lift station shall be designed to handle the flows of the designated catchment area.
- .2 Type of station and impact on neighbours.
- .3 Construction dewatering requirements.

PLOT DATE: 98/04/30 10:15am RH

PROJ. CAD FILE No.: J:\STDD\ET\LYTTSD\F-5.DWG

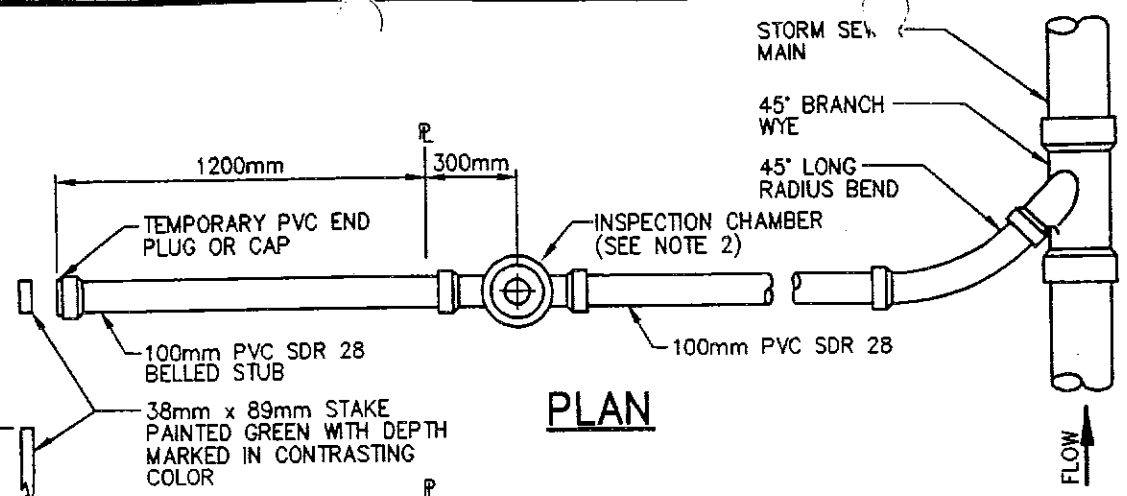

PLAN

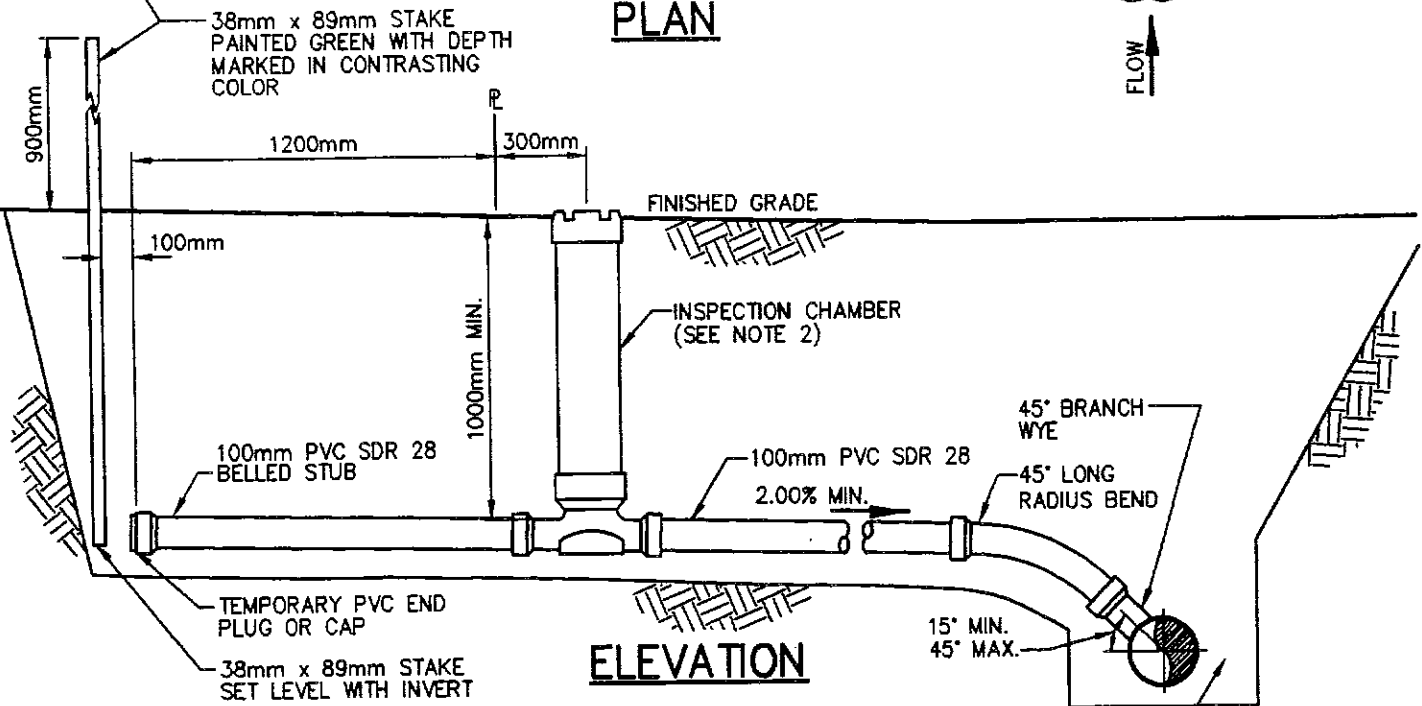

ELEVATION

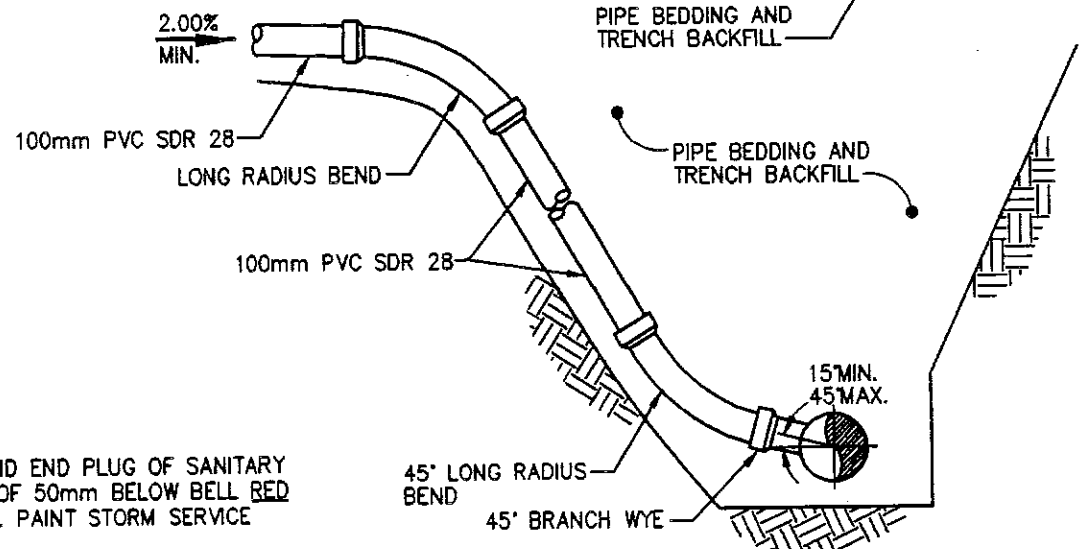

RISER TYPE CONNECTION

- NOTE:**
1. PAINT UPSTREAM BELL AND END PLUG OF SANITARY SERVICE FOR A MINIMUM OF 50mm BELOW BELL RED AT TIME OF INSTALLATION. PAINT STORM SERVICE GREEN.
 2. REFER TO SPECIFICATION DRAWING F-6 FOR INSPECTION CHAMBER DETAIL

<p>VILLAGE OF LYTTON</p>	SCALE: NOT TO SCALE		TITLE: TYPICAL SANITARY AND STORM SEWER SERVICE CONNECTION	
	DATE DRAWN: MAR. 1998	LATEST REVISION DATE: MAR. 1998		
	APPROVED BY: <i>Madig</i>		SECTION: SCHEDULE F SANITARY SEWER	REVISION No. 0

PLOT DATE: 98/04/30 10:40am RH

PROJ. CAD FILE No.: J:\STDD\ET\LYTTSD\F-6.DWG

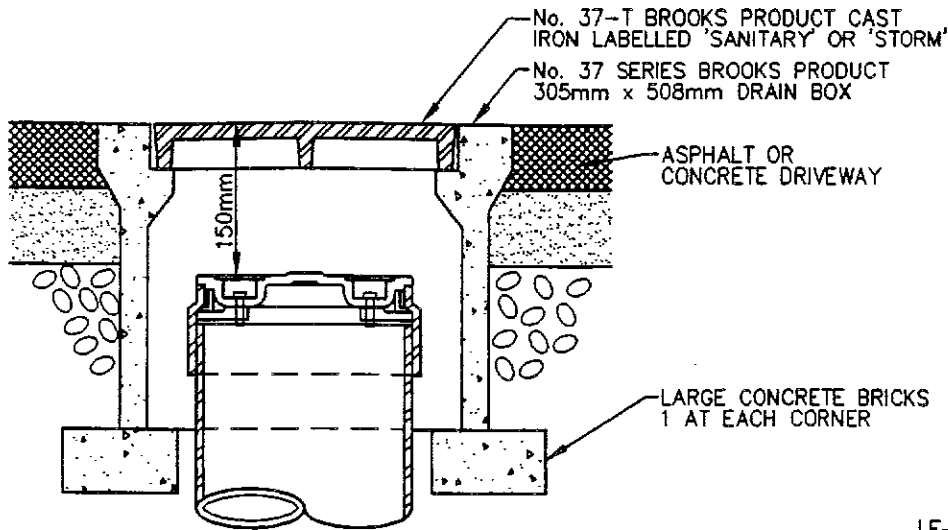

INSTALLATION IN DRIVEWAY

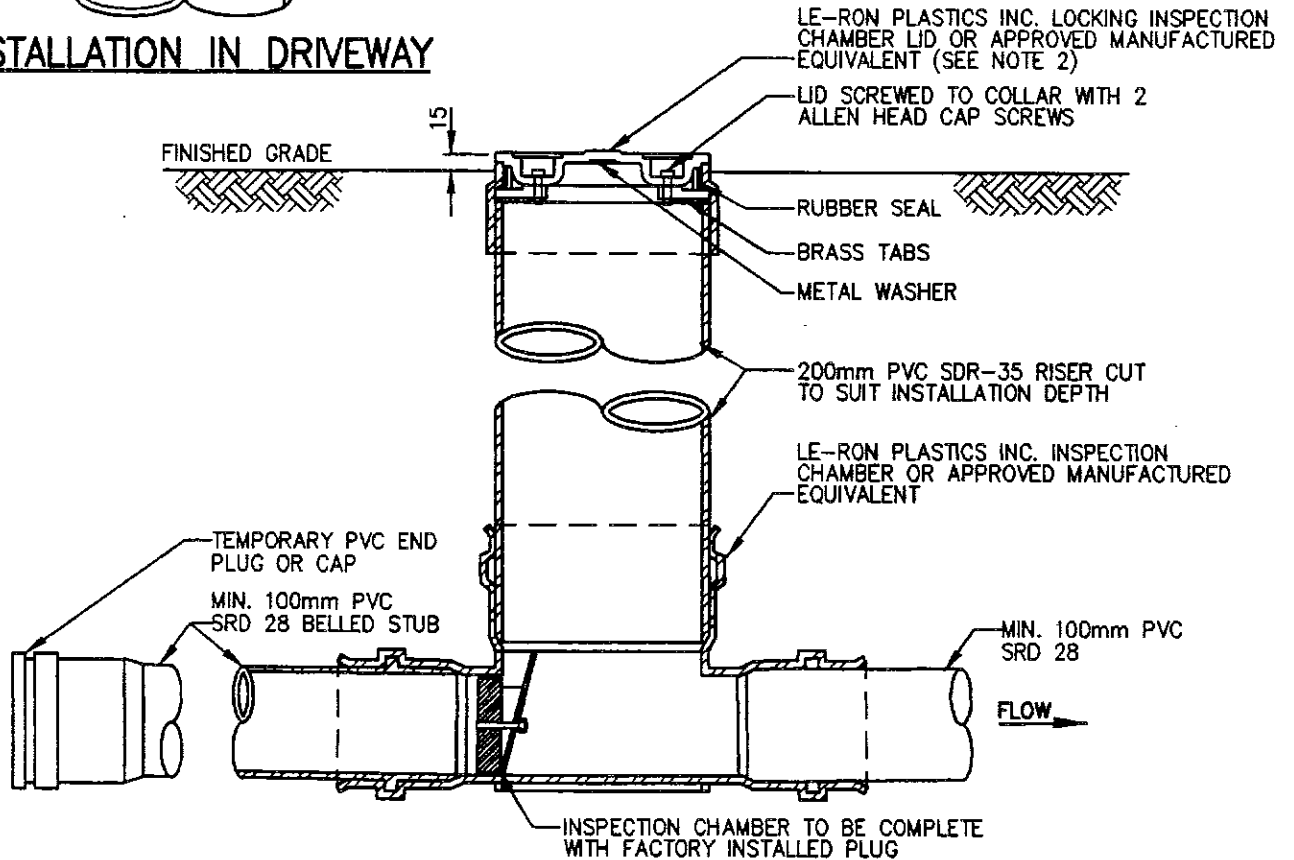

INSTALLATION IN BOULEVARD

- NOTES:
1. PAINT UPSTREAM BELL AND END PLUG FOR A MINIMUM OF 50mm BELOW BELL, AT TIME OF INSTALLATION AS FOLLOWS:
 - SANITARY SERVICE RED
 - STORM SERVICE GREEN
 2. PAINT INSPECTION CHAMBER LID AS FOLLOWS:
 - SANITARY SERVICE RED
 - STORM SERVICE GREEN

<p>VILLAGE OF LYTTON</p>	SCALE: NOT TO SCALE		TITLE: INSPECTION CHAMBER FOR SERVICE CONNECTIONS	
	DATE DRAWN: MAR. 1998	LATEST REVISION DATE: MAR. 1998	SECTION: SCHEDULE F SANITARY SEWER	
	APPROVED BY: <i>Amadio</i>			

- .4 Access for construction and maintenance complete with asphalt driveway or approved equivalent of sufficient strength to handle heavy trucks and with enough space to turn around.
- .5 Aesthetics, noise, odour, and landscaping requirements.
- .6 Security against vandalism and theft.
- .7 Flood elevations. Station uplift design shall be based on maximum flood level.
- .8 Proximity of receiving sewers, watermains, and adequate power supply.
- .9 Minimizing energy requirements.
- .10 Standby power and its requirements and compatibility.
- .11 Soils investigation shall be undertaken prior to site approval being given.
- .12 Convenience of operation and maintenance.
- .13 Safety of operators and the public.
- .14 Capital costs and operation and maintenance costs.

F - 2.11 Design Requirements

All sewage lift stations shall meet the following design requirements.

- .1 Pumps shall meet maximum flow condition with one pump in failure mode. The pump shall handle the maximum flow with the smallest impeller for that pump size to allow for any future expansion. Pump specifications should be approved by the Approving Officer.
- .2 Pumps shall operate alternately. However, a further safety feature shall allow for both pumps to operate at the same time during extreme flows.
- .3 Pumps shall have non-clog impellers that will pass a 60 mm minimum spherical solid.
- .4 Control panel shall be mounted in the dry well or in a suitable kiosk on a concrete pad and it shall contain a Crouse Hinds receptacle with reverse contacts and manual transfer switch suitable for connecting standby power at 347/600 volts and should be capable of handling the pumps with the largest impeller installed and running simultaneously. An extra power outlet for small hand tools operating at 110/220 volts is also required.

- .5 Sloping bottom and filleted corners in wet well to direct the flow to the pump suction inlet and prevent solids deposition.
- .6 Minimum 38 mm stand pipe water supply within 10 m of the station for washdown complete with a pressure reducer (if required), a backflow preventer, and a ball shutoff valve. Water supply to be installed outside the pump entrance, below the frost line, in an accessible chamber. Back flow preventers must be installed.
- .7 Liquid level sensing system EHN-10 float switches as provided by Flygt Canada Ltd. or an equivalent acceptable to the Approving Officer.
- .8 Compatible telemetering system.
- .9 Emergency pump-out arrangement approved by the Approving Officer.
- .10 Sufficient access to remove components for repair.
- .11 Pipe vent with vandal proof insect screen on outlet for the ventilation of the wet well. Explosion-proof exhaust fan which has sufficient capacity to exchange the total volume of air inside the well with fresh air within 3 minutes.
- .12 Check valve and isolating valve for each pump must be provided. Where possible, locate valves in a horizontal position. Where surge pressures for the check valve would be excessive, an electric activated slow closing resilient seated eccentric plug valve, with battery standby, shall be used.
- .13 A Workers' Compensation Board approved aluminum or galvanized steel ladder for access to wet well and dry well.
- .14 Sump pump for the interior of the dry well discharging above the TWL in the wet well.
- .15 Minimum 2 hour storage between the high level alarm and the start of overflow to be provided within the wet well, influent pipes and surface ponds at peak wet weather flow. Surface ponds are only to be used on approval of the Approving Officer and must be adequately secured with chain link fencing.
- .16 The wet well shall be sized to allow a minimum of 3 minutes to elapse between successive pump starts at peak flow conditions to prevent pump burn-out.
- .17 Emergency overflow should prevent flooding of buildings connected to the sewer system and prevent damage of components in the lift station. Overflow should be to a confined storage area.

- .18 All equipment must be CSA approved.
- .19 An explosion proof light with protective cover activated by a switch inside the kiosk should be provided.
- .20 Gate valve on the pressure line from the pump station is required.
- .21 Bell mouth on pump intake required on all dry well pumps.
- .22 Inside deck plates to be light weight fibre glass or aluminum complete with stainless steel hinges. Open grate deck plates preferred.
- .23 Special flex joints shall be used at the inlet pipe such as Flex-Tend by EBAA Iron Inc. or an approved equivalent.
- .24 The outlet pipe and all other connections to the station shall be brought to within 1.5 m of the expected ground line around the pump station by the use of risers either on the inside of the station or attached to the outside of the station.
- .25 Particular criteria for submersible and for dry well stations are to be reviewed with the Approving Officer.
- .26 For each design submission to the Village, an extra set of drawings pertaining to the design of the pump station, the sanitary mains and forcemains, keyplan and a location plan shall be submitted for the maintenance department to review.
- .27 Before commencement of construction, the Design Engineer shall provide five sealed sets of mechanical shop drawings and five sealed sets of electrical line diagrams for review by the Approving Officer. Two sealed copies of design calculations shall be provided for documentation. Before acceptance of the completed lift station, by the Village, the Design Engineer shall provide 3 copies of an Operation and Maintenance Manual to the Village. The manual shall contain:
 - .1 Cover page and table of contents.
 - .2 As constructed shop drawings.
 - .3 Equipment layout drawings.
 - .4 Electrical, control, and alarm wiring diagrams.
 - .5 Operating instructions for all equipment.
 - .6 Maintenance instructions for all equipment, including frequency of maintenance tasks.
 - .7 Equipment data sheets.
 - .8 Certified head/capacity curves for pumps.
 - .9 Equipment part lists.

.10 Emergency operating procedures.

The maintenance manuals shall be hardbacked bound documents with the name of the facility embossed on the cover. Each section of the manual shall be identified by plastic covered, tabbed dividers, with the section name identified on the tab.

F - 2.12 Access

An all weather vehicular access shall be provided to all reservoirs and pump stations. The access roads shall conform to the following standards:

- .1 minimum surface width – 6 m;
- .2 ditching along both sides to at least 100 mm below sub-grade;
- .3 300 mm pitrun gravel sub-base; and
- .4 50 mm crushed gravel base.

F - 2.13 Force Mains

At the lowest pump delivery rate anticipated to occur at least once per day, a cleansing velocity of at least 0.9 m/s should be maintained. Maximum velocity should not exceed 3.5 m/s.

An automatic air relief valve shall be placed at high points in the force main to prevent air locking.

Force mains should enter the gravity sewer system at a point not more than 600 mm above the flow line of the gravity sewer.

The minimum size for mains discharging raw sewage shall be 100 mm diameter.

The materials selected for force mains shall meet Village standards and shall adapt to local conditions, such as character of industrial wastes, soil characteristics, exceptionally heavy external loadings, abrasion and similar problems. Ductile iron shall be used from the pump station to the edge of the excavation and under creeks or ditches or, if desirable, an encasement pipe shall be used.

Other than for ductile iron forcemains, a trailing wire shall be installed for the purpose of locating the forcemain.

All force mains shall be designed to prevent damage from superimposed loads, or from water hammer or column separation phenomena.

F - 2.14 Tie-ins to Existing Sewer Mains

Connection of a new pipe to an existing mains shall be undertaken by the Village who will supply and install all materials to construct the connections. The cost of the connections will be charged to the Owner by the Village.

F - 2.15 Pipe Class and Bedding Class

The quality of pipe and bedding shall be so selected such that the installation will adequately support the loads to be placed on it during construction and in operation. For concrete pipe, the calculations shall follow the method shown in *Water Pollution Control Federation Manual of Practice No. 9*, latest edition. A safety factor of 1.5 shall be used for concrete pipe and the bedding classifications shall be as identified on the Standard Drawing.

For PVC pipe, the calculations shall follow the methods outlined in the Uni-Bell Plastic Pipe Association publication *Handbook of PVC Pipe - Design and Construction*, latest edition.

Pipe class and bedding class must be identified on all engineering drawings. Pipe shall have at least Class B bedding.

F - 3.0 MATERIALS

F - 3.1 Pipe and Fittings

- .1 Pipe for gravity sanitary sewer mains and large services shall be Polyvinylchloride (PVC) pipe S.D.R. 35, conforming to ASTM D3034 and CSA B182.2, stiffness (F/Y) of 320 kPa at 5% deflection conforming to ASTM D2412, complete with approved rubber gasket joints. Maximum pipe length shall be 4 metres.
- .2 Pipe for 100 mm and 150 mm sanitary sewer connections shall be Polyvinylchloride (PVC) pipe, S.D.R. 28, conforming to ASTM D3034 and CSA B182.1, complete with rubber gasket joints. Maximum pipe length shall be 4 metres.
- .3 Sewer fittings shall correspond with the respective main and service pipes and shall be consistent with the specification for main pipe.
- .4 Pipes and fitting for sanitary sewer force mains shall be as approved for watermains in accordance with Schedule E, Section 3.01.
- .5 Pipes shall be as listed in on Approved Product List. Other types of pipe may be used only with the written consent of the Approving Officer.

F - 3.02 Pipe and Fitting Joints

Sewer pipe and fittings shall be jointed with a rubber gasket or other preformed, factory-manufactured gasket or approved material.

F - 3.03 Service Junctions

Connection of services to new sewer mains shall be made using a wye. The type of joint of the service connection pipe to the sewer main shall conform with the type of joints on the sewer main.

Service wye saddles shall only be used to connect a 100 mm or 150 mm diameter service to an existing main. Where service saddles are used, they shall be equipped with stainless steel straps. Service saddles shall only be used with the approval of the Approving Officer.

F - 3.04 Manholes

Precast concrete manhole sections shall conform to ASTM C478 and shall be minimum 1050 mm diameter with 115 mm wall thickness for mains less than 450 mm diameter; for mains greater than 450 mm diameter, the precast manhole sections shall conform to the diameters specified on the applicable Standard Drawings. Concrete for cast-in-place manholes shall have a minimum compressive strength of 20 Mpa at 28 days.

Concrete for cast-in-place manhole bases and benching shall have a minimum compressive strength of 20 Mpa at 28 days.

Precast manhole bases of a design and construction quality acceptable to the Approving Officer will be accepted in lieu of cast in place bases.

Cover slabs shall be precast reinforced concrete to withstand H-20 loading conditions. Cover slabs shall have minimum 760 mm opening.

Manhole rungs shall be 20 mm diameter steel, hot dipped galvanized after bending, or an approved aluminum alternate, at 300 mm o.c., cast into the wall of the manhole section, or set in 30 mm holes filled with epoxy cement. Rungs shall protrude 125 to 150 mm from the manhole wall. If precast manhole barrels are used having inset wire lifting lugs, the lugs shall be galvanized.

F - 3.05 Manholes Frames and Covers

Covers and frames shall be cast iron of an approved pattern to withstand H2O loading. The cover shall have a minimum 610 mm clear opening and have a weight of 106 Kg and a weight of 80 Kg. Bearing faces of the cover to frame shall be machined to prevent rocking. The cover shall have 2 - 25 mm diameter lifting holes. The lid shall be embossed with "Sanitary Sewer".

F - 3.06 Bedding Material

Bedding shall for all pipe bedding shall be sand or crushed rock free of clay lumps, organic and other deleterious material. Gradation shall conform to the gradation limits set out in Schedule E, Clause 3.13.

Through areas of high groundwater and/or unstable ground conditions, crushed gravel and drain rock shall be installed to bed the pipe.

F - 3.07 Backfill Material in Pipe Zone (Pipe Surround)

Backfill material in the pipe zone (pipe surround) shall be sand or crushed rock free of clay lumps, organic and deleterious material. Gradation shall conform to the gradation limits set out in Schedule E, Clause 3.13.

F - 3.08 Backfill Material Above Pipe Zone

In Road Areas

- .1 Backfill material below the pavement structure for trenches in road areas may be native soil that is free of organic or foreign matter and can be readily compacted to a minimum of 95% Standard Proctor density in compliance with ASTM D-698. Native material is not acceptable if it will not provide a competent base for roadwork. Maximum particle size of backfill material shall not to exceed 200mm.

If the native material is deemed unacceptable, the backfill material shall be imported granular material conforming to Clause 3.01 of Schedule C.

In Non-Road Surfaces:

- .2 Backfill material for trenches and easements or other non-road areas may be native material excavated from the trench providing it is sufficiently free of frozen soil, roots or other objectionable material so as not to cause undue settlement. Maximum particle size of backfill material not to exceed 200 mm.

F - 3.09 Encasement Pipe Filler Sand

To be well graded, clean sand, free from organic materials and conforming to the following to gradation limits;

**TABLE F-2
ENCASEMENT PIPE FILLER SAND GRADATION LIMITS**

Sieve Designation	Percent By Weight Passing
4.750 mm	100
1.360 mm	20 - 70
1.180 mm	13 - 50
0.850 mm	8 - 35
0.300 mm	5 - 25
0.150 mm	2 - 15
0.075 mm	0 - 8

F - 4.0 WORKMANSHIP

F - 4.01 Trench Excavation

Trenches shall be excavated in accordance with Workers' Compensation Board requirements to suit the cross-section shown on the applicable Standard Drawing. Open trenches through existing paved surfaces will be allowed only with the prior express consent of the Approving Officer. When trenches are permitted through existing pavement areas, the pavement shall be saw-cut in straight continuous lines parallel to the trench centreline prior to the commencement of trenching operations. Cages shall be used where practical to reduce the width of trench excavation and provide adequate safety for workers.

If trenches are excavated wider than the specified widths, a higher class of pipe or special bedding may be required.

Rock excavation in trenches shall provide a minimum clearance of 150 mm below the pipe for pipes 600 mm in diameter or less, and 250 mm for pipes larger than 600 mm in diameter.

Excavation for manholes, fittings and other appurtenances shall be to the lines which will permit the assembly of these sections and to permit adequate backfill and compaction.

Where an existing structure or underground installation may be affected by the works, it is the responsibility of the Owner to inform the owner of such facility sufficiently in advance that the owner may make an inspection and specify the protective measures to be undertaken.

Where an unforeseen or other obstruction is encountered which interferes with the designed alignment or grade, the construction shall cease until such time as revised proposals are approved by the Approving Officer.

Any over-excavation of the trench subgrade beyond the specified depth shall be backfilled with select material and compacted to 100% Standard Proctor density.

In areas of clay or other impermeable soils, where overexcavation of the trench subgrade is required, the overexcavation shall continue to a point where ponding of water in the trench bottom will be avoided.

F - 4.02 Tie-Ins to Existing Sanitary Sewer

Tie-ins to existing sanitary sewer mains shall not be made until after new lines have been flushed and tested.

The Owner shall install plugs in the nearest manhole to each connection so that no water enters the existing sewer system. The plugs shall be left in place until final connection and acceptance of the new works by the Village. No turning in of sewage to the new system shall be done until the new works have been flushed and approval obtained from the Village. The Owner shall be charged a minimum of \$500.00 for each time he allows water or sewage from the new system to enter the existing system plus any additional costs for cleaning the existing sewers or any additional costs for cleanup or for repair of damage to the existing sewers, appurtenances, flooded buildings, or the sewage treatment plant.

F - 4.03 Pipe Installation

Prior to installing pipe all standing water shall be drained or pumped from the trench.

Pipe shall be carefully lowered into the trench in a manner that will prevent damage to the pipe. Pipe shall be jointed in strict accordance with the manufacturer's recommended practice. When pipes are not being installed, the open end of the newly laid pipeline shall be protected with a suitable bulk head to prevent the entry of any foreign material.

Trench conditions shall be such that pipe jointing can be accomplished without getting muck, silt, gravel and other foreign material into the pipe.

The grade of every pipe length shall be checked before the pipe is backfilled. Any part of the trench excavated below grade shall be regraded with approved material thoroughly compacted.

All pipe must be laid to the design lines and grades within the following tolerances:

- .1 Horizontal deviation from the approved alignment shall not exceed 60 mm and the rate of deviation shall not exceed 40 mm in 10 metres.
- .2 Vertical deviation from true grade varies with the grade and shall not exceed the limits shown in the following table:

**TABLE F-3
SANITARY SEWERMAIN VERTICAL TOLERANCE LIMITS**

Grade	Max. Departure From Design Elevation	Max. Rate of Deviation
Over 5%	30 mm	20 mm in 10 metres
2% to 5%	15 mm	10 mm in 10 metres
Less than 2%	6 mm	10 mm in 10 metres

F - 4.04 Granular Bedding and Backfill in Pipe Zone

The pipe zone is considered as being the depth of trench between the trench bottom and a level 300 mm above the top of the pipe.

The pipe zone backfill shall be hand placed and thoroughly compacted to a density of 95% Standard Proctor Density in layers not exceeding 150 mm using hand tampers.

F - 4.05 Backfill Above Pipe Zone

In Road Areas

- .1 In road areas trench backfill material shall be placed in layers not exceeding 300 mm in thickness and compacted by mechanical means to a minimum of 95% Standard Proctor density.

The water content of the material shall be controlled to achieve the required density.

In Non-Road Areas

- .2 In easements and other non-roads areas, native trench material may be used for trench backfill above the pipe zone. Backfill shall be placed and compacted to 90% Standard Proctor Density.

F - 4.06 Manholes

Manholes shall be constructed as shown on the applicable Standard Drawings.

All water shall be removed from the excavation prior to placing concrete. Concrete shall be placed only on a firm base. If the bottom of the excavation is unsuitable for support, it shall be excavated to a firm base and backfilled to the required grade with pipe bedding material.

'GU' liners or an approved equal shall be installed in all manholes.

Precast sections shall be placed plumb with a bitumastic compound placed between the joints to exclude the entrance of groundwater.

Drop structures shall be constructed as shown on the applicable Standard Drawing.

F - 4.07 Stubs

Blind stub sections for connection of future sewers to the manholes shall be installed as directed by the Approving Officer. The stub shall be plugged at the end with a watertight removable plug.

F - 4.08 Service Connections

- .1 Sanitary sewer service connections shall be installed in accordance with the applicable standard drawings, and shall comprise:

- a wye fitting connection to the sewer main;

- a large radius sweep between the wye and the start of the service pipe;
- 100 mm or 150 mm PVC DR 28 building sewer service pipe;
- a Le-Ron Inspection Chamber installed 0.30 m from the property line, the lid of the inspection chamber shall be painted red;
- a minimum 2.0 m length of pipe shall extend into the lot; the end of the pipe and the end cap shall be painted with red paint; and
- a 50 x 100 mm marker stake shall be set at the end of the sewer service pipe (end cap) with the bottom of the stake set flush with the invert of the service pipe. The marker stake shall be set perfectly plumb, extend at least 1.0 m above the grade surface, be painted red, and have the distance between the top of the stake and the service invert clearly marked in metres with a black felt pen.

.2 All sanitary sewer services shall be tested with the mains.

F - 4.09 Pipe Casings

Pipe casings shall be installed as shown on the applicable Standard Drawing. The sewer pipe shall be blocked at each joint to ensure line and grade is maintained and the casing is to be sealed at both ends with joint filler with proper care taken to ensure that the pipe remains on line and grade and does not float. The annular space between the sewer pipe and the casing pipe shall be filled with 14 mm sand, as specified in Section F - 3.09.

A length of 6 mm polypropylene rope shall be laid alongside the carrier pipe inside the casing to assist future retrieval.

F - 4.10 Asphalt Restoration

If the edges of the cut asphalt have become ragged as a result of the construction operation, asphalt shall be saw-cut to form a straight line prior to placing new asphalt. The edges of the existing asphalt shall be thoroughly cleaned and coated with an approved bituminous bonding agent prior to placing the hot asphalt mix. The finished grade of the asphalt surface shall conform with that of the existing surface such that no rises, depressions or ridges result from the repaving process.

F - 4.11 Cleaning and Flushing

Prior to testing, the sanitary sewer pipe shall be cleaned by flushing, or the use of mechanical equipment as necessary to remove all foreign material from the pipe. After paving and landscaping and before subdivision acceptance, the sanitary lines shall be flushed to remove any deleterious material deposited by associated construction works. No water from the flushing and cleaning process shall enter the existing service system.

F - 4.12 Force Mains

Force mains shall be constructed and tested in accordance with Schedule E or as specified by the Approving Officer.

F - 4.13 Leakage Tests

Lamping

Sewer mains shall be lamped from manhole to manhole to check alignment and grade of the sewer pipe. Variations in line or grade from that shown on the approved construction drawings and any jointing, pipe cleaning, or other deficiencies discovered shall be rectified. Manholes shall be inspected and any defects or deficiencies found shall be rectified.

Sewer Mains

Sewer mains shall be tested by a low pressure air test.

Pipe mains and services shall be clean and plugged in preparation for the test. An air supply system should have adequate valves to isolate the test section and to vent off excess air. Pressure gauges should be clean and functional. Adequate blocking shall be placed behind all plugs to prevent plugs from blowing out. Blocking should allow the plugs to move approximately 6 mm.

If the ground water level with respect to the pipe is not known, this level shall first be determined at the lowest point of the line under test. The external ground water pressure shall then be calculated (depth of ground water in meters above invert of pipe multiply by 9.8 = pressure in KPa).

The section of pipeline under test shall be gradually surcharged to a pressure of 27.6 KPa above ground water pressure as determined above. Time will be allowed for the air temperature to stabilize (not less than 5 minutes). If the pressure drops below 24.2 KPa (pressure refers to the amount of pressure above ground water pressure), the 24.2 KPa pressure shall be maintained from the make-up air supply. If the pressure does not drop to 24.2 KPa during the period of stabilization, the air shall be released slowly until the pressure drops to 24.2 KPa.

The time is then measured for the period that the resultant air pressure drops 6.9 KPa from 24.2 to 17.3 KPa. If the time measured equals or exceeds the specified time, the test may be stopped, the readings recorded, including pressure readings, and the test considered satisfactory.

The time specified shall be as per Table F.4. If the time measured does not equal or exceed the specified time, the section of sewer main shall be checked for excessive leakage, and after repairs are made the pipeline shall be retested in the same manner.

TABLE F.4
MINIMUM AIR PRESSURE/LEAKAGE TEST TIME

Pipe Diameter (mm)	Time in Minutes
100	2 min. 30 sec.
150	3 min. 45 sec.
200	5 min. 00 sec.
250	6 min. 16 sec.
300	7 min. 30 sec.
375	9 min. 22 sec.
450	11 min. 15 sec.
525	13 min. 08 sec.
600	15 min. 00 sec.

Manholes

Upon the entire completion of the manhole installations, watertight plugs or seals shall be inserted on inlets and outlets of each new sanitary sewer manhole. The manhole filled to the underside of the top concrete slab. The water level shall be recorded at the beginning and end of the 2 hour test period and the leakage shall not exceed 0.3% of the manhole volume per hour. If the permissible leakage is exceeded, defects shall be corrected and the test repeated until the installation is acceptable. Plugs and water shall be removed after the test.

F - 4.14 Materials Testing

The Village shall be provided with copies of all sieve compaction test results pertaining to bedding, backfill and road restoration.

F - 4.15 Video Inspection Tests

Before paving of asphalt surfaces, all sewer mains shall require a closed circuit televised inspection by the Owner to check jointing, possibility of debris in the pipe, leakage, alignment and grade of the sewer pipe. Any deficiencies discovered shall be rectified prior to paving.

Television equipment shall consist of a self contained camera and a monitoring unit connected by a coaxial cable. This equipment shall be specifically designed and constructed for such inspection purposes. The camera shall be mounted on adjustable skids to facilitate the inspection of different sizes of pipe. The camera and skids shall be small enough to insure passage through a 150 mm dia. sewer. The camera shall be waterproof and shall have a remotely controlled adjustable self-contained lighting system capable of producing at least 100 foot candles of light. The lighting system shall be capable of lighting the entire periphery of the pipe.

Picture quality shall be such to produce a continuous 500 line resolution picture showing the entire periphery of the pipe. Picture quality and definition shall be to the satisfaction of the Approving Officer.

Measurement of defects shall be made by devices having a proven accuracy of plus or minus one percent. Cable markings if used, shall not be spaced at a distance of more than 600 mm along the length of the cable. Any type of measurement system used shall be subject to inspection by the Approving Officer.

Direct voice communication shall be established between the monitoring station and the camera towing device. This may be accomplished by a direct line of communication or radio. No loudspeaker devices shall be allowed.

Equipment shall be mounted in an appropriate type vehicle. Electrical power for the system shall be self-contained and shall not require removal for each set-up. External power sources from public or private residences shall not be permitted. Ample sound dampening shall be applied to the vehicle and equipment.

A television work report, in log form, shall be maintained during the inspection. This log shall show the exact location of each leak or fault discovered by the television - e.g. open joints, broken, cracked or collapsed pipe, presence of grease, roots, debris, accumulation, obstructions, infiltration, water depth variations, and other points of significance. The reference location shall include the distance away from the reference manhole and also the position of the leak or fault as referenced to the crown of the pipe using clock face notation.

The report shall include the location of all service connections together with a statement of opinion as to whether or not the service connections are leaking. Protrusions of the service connections into the mainline shall be noted with reference to the degree of protrusion.

Photographs of all sewer defects shall be taken. The photographs shall be co-ordinated with the written report by reference numbers. A minimum of one photograph per line shall be taken to show a representative view of the workmanship, as well as additional photographs of deficiencies as required.

Each manhole section of pipe shall be located on the report form in such a way as to be readily identifiable. Identify such items as name of subdivision, street names, manhole numbers, type of pipe, joint length, direction of flows, pipe diameter, manhole depth, inspection date, names of the inspection technician, persons viewing, and video tape identification numbers.

Three copies of a final typewritten report with corresponding photographs and one copy of video tapes shall be furnished to the Approving Officer within two weeks after the completion of the inspection. This report shall contain no less than one photograph per manhole section inspected and additional photographs as required to show line faults and representative line conditions.

Full colour video tapes shall be of a format acceptable to the Approving Officer. All video tapes shall be numbered and cross indexed to the typewritten report. Video tape footages to fault locations shall also be cross indexed to the typewritten report, as well as referenced to the description of the fault included on the video tape. Tapes shall be in the VHS format.

To insure photographic quality 35 mm still photographic cameras shall be designated. Polaroid or similar cameras that do not produce negatives for rapid reproduction will not be acceptable. All still photographs shall be in colour.

If, during the inspection procedures the television camera will not pass through the entire manhole section, the equipment shall be reset in a manner so that the inspection can be performed from the opposite manhole.

Prior to inspection, all lines shall be cleaned thoroughly to remove dirt, grease, sand and other foreign and objectionable debris from inside the pipe and manholes so that cracks and other faults may be observed.

A small diameter poly rope or similar line shall be installed in the sewer in advance of the inspection in order that the camera traction cable may be drawn through the sewer. This line shall be installed on a manhole to manhole basis with the line being tied off at each individual manhole to facilitate the quick removal of any portion of this line should the need arise due to mainline sewer blockages or other emergency situations.

Interference to the normal flow of traffic shall be kept to a minimum. The equipment shall be arranged so that one lane of traffic is maintained at all times.

F - 4.16 Construction Record Drawings

Prior to final acceptance, the Owner shall deposit with the Village one computer zip diskette (3½") in AutoCAD (latest release) format and one set of original construction record mylar drawings showing all the information requested by this schedule and conforming to the criteria set out in Schedule I.